



SIMCOM WCDMA Wireless Module PCM Application Note_V1.01



Document Title:	PCM Application Note
Version:	1.01
Date:	2010-03-29
Status:	Release
Document Control ID:	PCM Application Note_V1.01

General Notes

SIMCom offers this information as a service to its customers, to support application and engineering efforts that use the products designed by SIMCom. The information provided is based upon requirements specifically provided to SIMCom by the customers. SIMCom has not undertaken any independent search for additional relevant information, including any information that may be in the customer's possession. Furthermore, system validation of this product designed by SIMCom within a larger electronic system remains the responsibility of the customer or the customer's system integrator. All specifications supplied herein are subject to change.

Copyright

This document contains proprietary technical information which is the property of SIMCom Limited., copying of this document and giving it to others and the using or communication of the contents thereof, are forbidden without express authority. Offenders are liable to the payment of damages. All rights reserved in the event of grant of a patent or the registration of a utility model or design. All specification supplied herein are subject to change without notice at any time.

Copyright © Shanghai SIMCom Wireless Solutions Ltd. 2010

Contents

Contents	3
Version history	5
1 Introduction	6
2 Scope of the document	6
3 SIM52XX PCM overview	7
3.1 Hardware PCM	7
3.2 Software PCM	7
4 Hardware PCM interface	8
4.1 PCM mode	8
4.2 Auxiliary PCM	8
4.3 Primary PCM	10
5 AT command about PCM	11
5.1 AT+CSDVC Switch voice channel device	11
5.2 AT+CPCM External PCM codec mode configuration	13
5.3 AT+CPCMFMT Change the PCM format	14
5.4 AT+ DSWITCH Change diagnostics port mode	14
5.5 AT+CPCMREG Control PCM data transfer by diagnostics or NEMA port	15
6 PCM codec selecting guide	16

Figure Index

FIGURE 1: AUX_PCM_SYNC TIMING.....	9
FIGURE 2: AUX_PCM_CODEC TO SIM52XX TIMING	9
FIGURE 3: SIM52XX TO AUX_PCM_CODEC TIMING	9
FIGURE 4: PRIM_PCM_SYNC TIMING.....	10
FIGURE 5: PRIM_PCM_CODEC TO SIM5218A TIMING	10
FIGURE 6: SIM52XX TO PRIM_PCM_CODEC TIMING.....	11

SIMCOM CONFIDENTIAL FILE

Version history

Date	Version	Description of change	Author
2010-03-23	01.00	Origin	

SIMCOM CONFIDENTIAL FILE

1 Introduction

SIM52XX provides 2 PCM interface: hardware and software. This document describes the PCM interface of SIMCOM WCDMA wireless module. (SIM52XX represents the series which is stated below.)

2 Scope of the document

This document is intended for the following versions of the SIMCom modules

- SIM5210
- SIM5211
- SIM5213/SIM5214
- SIM5215/SIM5216
- SIM5218
- SIM5220/SIM5222

3 SIM52XX PCM overview

3.1 Hardware PCM

SIM52XX provides hardware PCM interface for external codec. **PCM interface pins are multiplex on GPIOs (SIM5210/SIM5211/SIM5213/SIM5214/SIM5215/SIM5216/SIM5218) or audio input (SIM5220/SIM5222).**

Use AT+CPCM command to enable PCM function and configure the mode you want. The PCM interface is a 4 pin, digital interface that enables PCM communication between the Module and an external codec. SIM52XX supports 3 PCM formats: 8 bits (u-law or A-law) and 16 bits (linear). The table below shows the hardware PCM interface of different SIMCOM WCDMA wireless modules.

Module	AT Command	PIN	Note
SIM5210 SIM5211 SIM5213 SIM5214 SIM5215 SIM5216 SIM5218	AT+CSDVC=4 AT+CPCM=1	PCM_DIN/GPIO0 PCM_SYNC/GPIO2 PCM_CLK/GPIO3 PCM_DOUT/GPIO5	PCM interface are multiplex with GPIOs.
SIM5220 SIM5222	AT+CSDVC=4 AT+CPCM=1	PCM_DOUT/MICP PCM_SYNC/ MICN PCM_CLK/EARP PCM_DIN/ EARN	SIM5220 and SIM5222 PCM interface are different from these of other modules. Handset and PCM channel share the same hardware pins.

Table 1: PCM interface of SIMCOM WCDMA wireless modules

3.2 Software PCM

SIM52XX can transmit PCM data by USB.

For SIM5211/5213/5214/5215/5216, NEMA port is used to transmit PCM data.

For SIM5210/SIM5218/SIM5220/SIM5222, diagnostics port is used to transmit PCM data.

At first, one should make sure that driver of SIM52XX has been loaded on host part. Then the diagnosis or NEMA port of SIM52XX can be recognized by SIM52XX. One can switch it from debug mode to data mode or from data mode to debug mode by AT+DSWITCH. In data mode, one can control sending and receiving PCM data by AT+CPCMREG.

4 Hardware PCM interface

4.1 PCM mode

PCM mode	SYNC	CLK	MODE	Format	Slot
Auxiliary	8KHz	128KHz	Master	A-law(8 bits)	0~15(Changed by AT command)
Primary	8KHz	2.048MHz	Slave/Master	u-law(8 bits) linear(16 bits)	

Table 2: PCM mode

The default PCM interface on power up is the auxiliary PCM interface. Under PCM, the data is output on the rising edge of PCM_CLK and sampled at the falling edge of PCM_CLK. Primary PCM is disabled at power up or when RESET is asserted, but you can use AT command to enable the primary PCM mode.

PCM Interface can be operated in Master and Slave mode. When the PCM interface is configured, PCM Tx data will be routed from the external codec Mic through the DSP encode path in the Module. PCM Rx data will be routed through the DSP decode path to the external codec speaker. When using the PCM Interface, the Module can be set either into Master Mode or Slave Mode.

In Master Mode, the Module drives the clock and sync signals that are sent out to the external codec via the PCM Interface. When in Slave Mode, the external codec drives the clock and sync signals that are sent to the Module.

Configuration Mode can be selected either primary or auxiliary. Primary configuration mode uses 2.048MHz clock and 8kHz short sync clock, and auxiliary configuration mode uses 128kHz clock and 8kHz long sync clock. One important consideration is that Slave mode is only available for use with Primary configuration Mode. PCM formats can also be chosen by AT command.

4.2 Auxiliary PCM

The auxiliary PCM interface enables communication with an external codec to support hands-free applications. u-law codec are supported by the auxiliary PCM interface.

The auxiliary codec port operates with standard long-sync timing and a 128 kHz clock. The AUX_PCM_SYNC runs at 8 kHz with 50% duty cycle. Most u-law codec support the 128 kHz clock.

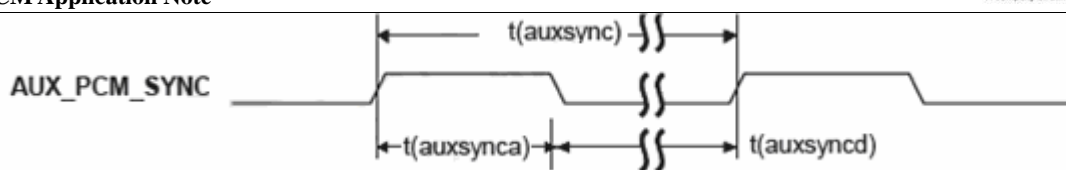

Figure 1: AUX_PCM_SYNC timing

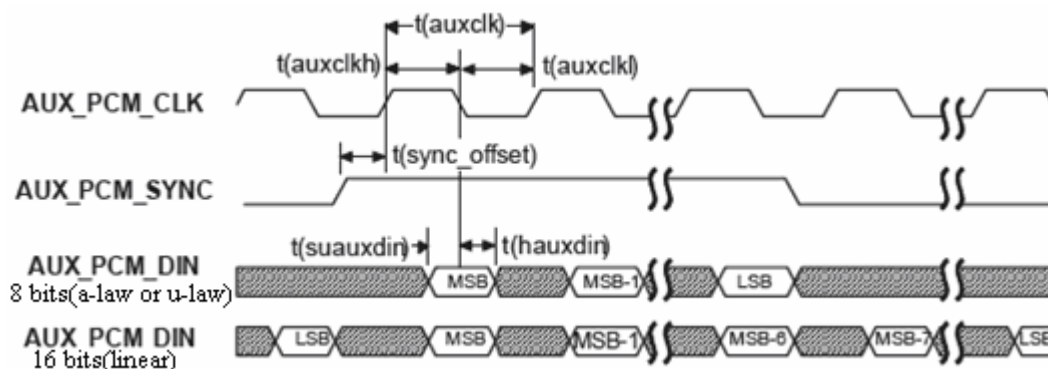

Figure 2: AUX_PCM_CODEC to SIM52XX timing

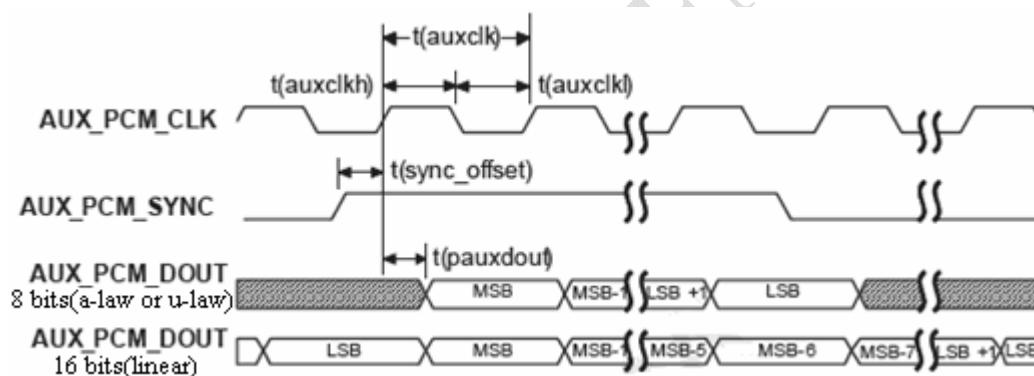

Figure 3: SIM52XX to AUX_PCM_CODEC timing

Table 3: AUX_CODEC timing parameters

Parameter	Description	Min	Typical	Max	Unit	Note
t(auxsync)	AUX_PCM_SYNC cycle time	–	125	–	μs	
t(auxsynca)	AUX_PCM_SYNC asserted time	–	62.5	–	μs	1
t(auxsyncd)	AUX_PCM_SYNC de-asserted time	–	62.5	–	μs	1
t(auxclk)	AUX_PCM_CLK cycle time	–	7.8	–	μs	2
t(auxclkh)	AUX_PCM_CLK high time	–	3.9	–	μs	3
t(auxckl)	AUX_PCM_CLK low time	–	3.9	–	μs	3
t(sync_offset)	AUX_PCM_SYNC offset time to AUX_PCM_CLK rising	–	1.95	–	μs	4
t(suauxdin)	AUX_PCM_DIN setup time to	60	–	–	ns	

PCM Application Note

	AUX_PCM_CLK falling					
t(hauxdin)	AUX_PCM_DIN hold time after AUX_PCM_CLK falling	60	–	–	ns	
t(pauxdout)	Propagation delay from AUX_PCM_CLK AUX_PCM_DOUT valid	–	–	60	ns	

Note:

1. $t(\text{auxsync})/2 \pm 10 \text{ ns}$.
2. $t(\text{auxclk}) = 1/(128 \text{ kHz})$.
3. $t(\text{auxclk})/2 \pm 10 \text{ ns}$.
4. $t(\text{auxclk})/4 \pm 10 \text{ ns}$.

4.3 Primary PCM

The aux codec port also supports 2.048 MHz PCM data and sync timing for μ -law codec that matches the sync timing — this is called the primary PCM interface (or just PCM interface). You can use AT+CPCM command to change the mode you want.

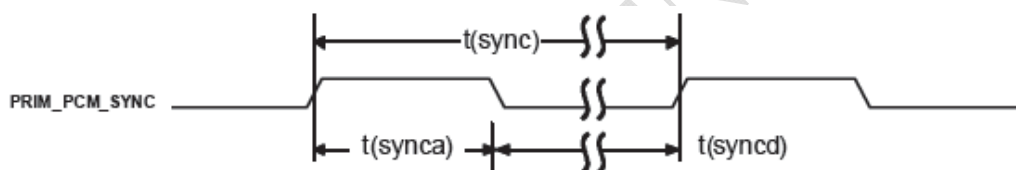

Figure 4: PRIM_PCM_SYNC timing

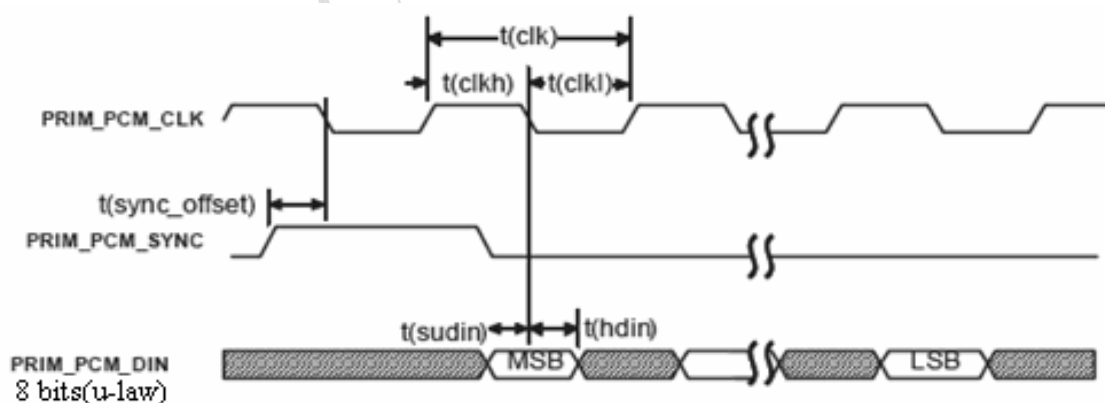

Figure 5: PRIM_PCM_CODEC to SIM5218A timing

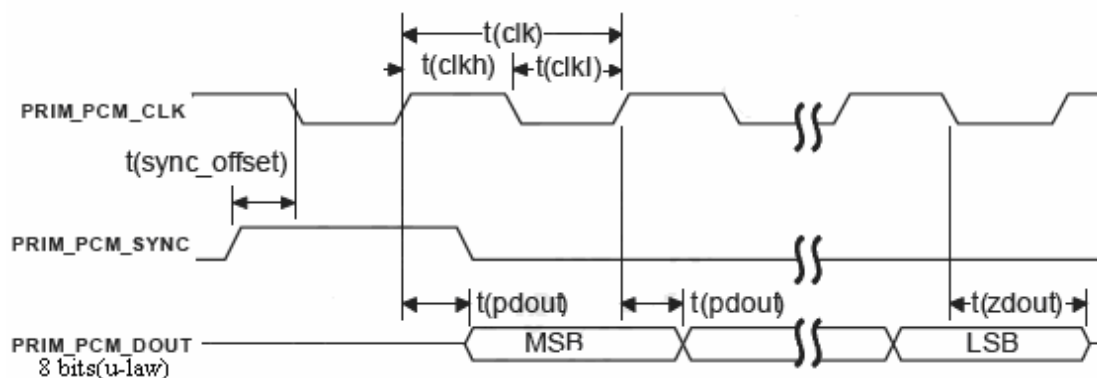

Figure 6: SIM52XX to PRIM_PCM_CODEEC timing

Table 4: PIM_PCM_CODEEC timing parameters

Parameter	Description	Min	Typical	Max	Unit	Note
t(sync)	PCM_SYNC cycle time	–	125	–	μs	
t(synca)	PCM_SYNC asserted time	–	–	–	ns	
t(syncd)	PCM_SYNC de-asserted time	–	–	–	μs	
t(clk)	PCM_CLK cycle time	–	–	–	ns	
t(clkh)	PCM_CLK high time	–	–	–	ns	
t(clkl)	PCM_CLK low time	–	–	–	ns	
t(sync_offset)	PCM_SYNC offset time to PCM_CLK falling	–	122	–	ns	1
	PCM_SYNC offset time to PCM_CLK falling	–	–	–	ns	
t(sudin)	PCM_DIN setup time to PCM_CLK falling	60	–	–	ns	
t(hdin)	PCM_DIN hold time after PCM_CLK falling	60	–	–	ns	
t(pdout)	Delay from PCM_CLK rising to PCM_DOUT valid	–	–	60	ns	
t(zdout)	Delay from PCM_CLK falling to PCM_DOUT High-Z	5	–	60	ns	

Note: 1. PCM_SYNC offset time = t(clk)

5 AT command about PCM

5.1 AT+CSDVC Switch voice channel device

Description

PCM Application Note

The command is used to switch voice channel device. After changing current voice channel device and if there is a connecting voice call, it will use the settings of previous device (loudspeaker volume level, mute state of loudspeaker and microphone, refer to [AT+CLVL](#), [AT+VMUTE](#), and [AT+CMUT](#)).

NOTE Use [AT+CPCM](#) command to enable PCM function and configure the mode that you want before setting [AT+CSDVC=4](#).

SIM PIN	References
NO	Vendor

Syntax

Test Command	Responses
AT+CSDVC=?	+CSDVC: (list of supported <dev> s) OK
Read Command	Responses
AT+CSDVC?	+CSDVC: <dev> OK
Write Command	Responses
AT+CSDVC= <dev> [, <save>]	OK

Defined values

<dev>
<ul style="list-style-type: none"> <u>1</u> – handset 2 – headset 3 – speaker phone 4 – PCM interface
<save>
<ul style="list-style-type: none"> <u>0</u> – temporary voice device setting, after reboot it will be resumed. 1 – permanent voice device setting.
NOTE If subparameter <save> is omitted, voice device setting is temporary.

Examples

AT+CSDVC=2
OK
AT+CSDVC?
+CSDVC:2
OK
AT+CSDVC=1,1
OK

5.2 AT+CPCM External PCM codec mode configuration

Description

The command will enable PCM or disable PCM function. And configure different PCM mode. Because the PCM pins are multiplex on GPIO, it will switch the function between GPIO and PCM.

SIM PIN	References
NO	Vendor

Syntax

Test Command	Responses
AT+CPCM=?	+CPCM: (list of supported <arg_1>s), (list of supported <arg_2>s) OK
Read Command	Responses
AT+CPCM?	+CPCM: <arg_1>,<arg_2> OK
Write Command	Responses
AT+CPCM=<arg_1>[,<arg_2>]	OK

Defined values

<arg_1>	
0	- disable PCM, switch to common GPIOs.
1	- enable PCM, switch to PCM function.
<arg_2>	
0	- Auxiliary master PCM, 128K clock and 8K synchronize clock.
1	- Primary master PCM, 2M clock and 8K synchronize clock...
2	- Primary slave PCM, clock provided by external codec.

Examples

```
AT+CPCM=1
```

```
OK
```

```
AT+CPCM=?
```

```
+CPCM : (0-1),(0-2)
```

```
OK
```

```
AT+CPCM?
```

```
+CPCM : 1,1
```

```
OK
```

5.3 AT+CPCMFMT Change the PCM format

Description

The command allows to change the current PCM format, there are 3 formats currently supported: linear, u-law, a-law

SIM PIN	References
NO	Vendor

Syntax

Test Command	Responses
AT+CPCMFMT=?	+CPCMFMT: (list of supported <format>s) OK
Read Command	Responses
AT+CPCMFMT?	+CPCMFMT: <format> OK
Write Command	Responses
AT+CPCMFMT=<format>	OK
	ERROR

Defined values

<format>	
0	u-law
1	a-law
2	linear

Examples

AT+CPCMFMT=?
+CPCMFMT: (0-2)
OK
AT+CPCMFMT?
+CPCMFMT: 1
OK
AT+CPCMFMT=2
OK

5.4 AT+ DSWITCH Change diagnostics port mode

Description

PCM Application Note

The command is used to change diagnostics port (SIM5210/SIM5218/SIM5220/SIM5222) or NEMA port (SIM5211/5213/5214/5215/5216) mode. The default mode of diagnostics port is debug mode. You can switch it from debug mode to data mode or from data mode to debug mode. In data mode, you can send and receive PCM data.

SIM PIN	References
NO	Vendor

Syntax

Test Command	Responses
AT+DSWITCH=?	+DSWITCH: (list of supported <mode>s) OK
Read Command	Responses
AT+DSWITCH?	+DSWITCH: <mode> OK
Write Command	Responses
AT+DSWITCH =<mode>	OK ERROR

Defined values

<mode>
Pamameter shows the settings of diagnostics port
0 Switch from data mode to debug mode
1 Switch from debug mode to data mode

Examples

```

AT+DSWITCH=?
+DSWITCH: (0-1)
OK
AT+DSWITCH?
+DSWITCH: 0
OK
AT+DSWITCH=1
OK
  
```

5.5 AT+CPCMREG Control PCM data transfer by diagnostics or NEMA port

Description

PCM Application Note

The command is used to control PCM data transfer by diagnostics port (SIM5210/SIM5218/SIM5220/SIM5222) or NEMA port (SIM5211/5213/5214/5215/5216). First you should set diagnostics or NEMA port as data mode by [AT+DSWITCH](#).

SIM PIN	References
NO	Vendor

Syntax

Test Command	Responses
AT+CPCMREG=?	+CPCMREG: (list of supported <n>s) OK
Read Command	Responses
AT+CPCMREG?	+CPCMREG: <n> OK
Write Command	Responses
AT+CPCMREG=<n>	OK ERROR

Defined values

<n>	
0	Disable PCM data transfer by diagnostics port
1	Enable PCM data transfer by diagnostics port

Examples

```

AT+CPCMREG=?
+CPCMREG: (0-1)
OK
AT+CPCMREG?
+CPCMREG: 0
OK
AT+CPCMREG=1
OK
  
```

6 PCM codec selecting guide

Before one select the PCM codec for SIM52XX, one should check whether the codec is compatible with SIM52XX PCM mode, which is shown below.

PCM Application Note

PCM mode	SYNC	CLK	MODE	Format	Slot
Auxiliary	8KHz	128KHz	Master	A-law(8 bits)	0~15(Changed by AT command)
Primary	8KHz	2.048MHz	Slave/Master	u-law(8 bits) linear(16 bits)	

PCM CLK of some codec can not support 128KHz. So if one want to use auxiliary PCM mode, one should check the codec PCM CLK.

PCM slot of SIM52XX should be same with that of PCM codec.

PCM format can also be set by command.

Before one open the PCM part of SIM52XX, AT+CSDVC=4, AT+PCM=1 should be entered to turn on the PCM CLK. Then when calling is setup, the PCM data can transmit by hard PCM interface.

SIMCOM CONFIDENTIAL FILE

Contact us:

Shanghai SIMCom Wireless Solutions Ltd.

Add: Building A, SIM Technology Building, No.633, Jinzhong Road, Changning District, Shanghai, P. R. China 200335

Tel: +86 21 3235 3300

Fax: +86 21 3235 3301

URL: www.sim.com/wm

SIMCOM CONFIDENTIAL FILE