



# SIMCOM WCDMA Wireless Module

## Audio Application Note\_V1.01



**Audio Application Note**

<b>Document Title:</b>	Audio Application Note
<b>Version:</b>	1.01
<b>Date:</b>	2010-03-23
<b>Status:</b>	Release
<b>Document Control ID:</b>	Audio Application Note_V1.01

**General Notes**

SIMCom offers this information as a service to its customers, to support application and engineering efforts that use the products designed by SIMCom. The information provided is based upon requirements specifically provided to SIMCom by the customers. SIMCom has not undertaken any independent search for additional relevant information, including any information that may be in the customer's possession. Furthermore, system validation of this product designed by SIMCom within a larger electronic system remains the responsibility of the customer or the customer's system integrator. All specifications supplied herein are subject to change.

**Copyright**

This document contains proprietary technical information which is the property of SIMCom Limited., copying of this document and giving it to others and the using or communication of the contents thereof, are forbidden without express authority. Offenders are liable to the payment of damages. All rights reserved in the event of grant of a patent or the registration of a utility model or design. All specification supplied herein are subject to change without notice at any time.

*Copyright © Shanghai SIMCom Wireless Solutions Ltd. 2010*

## Contents

Contents .....	3
Version history .....	5
1 Introduction .....	6
2 Scope of the document .....	6
3 Audio channel overview .....	7
4 Hardware Design.....	8
4.1 Speaker interface configuration .....	8
4.2 Receiver interface configuration .....	8
4.3 SIM5210 Microphone interfaces configuration .....	9
4.4 Microphone interfaces configuration (Except SIM5210).....	10
4.5 Earphone interface configuration .....	11
4.6 Referenced electronic characteristic.....	11
5 Audio Tuning .....	12
5.1 MIC volume and frequency response.....	13
5.1.1 AT+CMICAMP1 Set value of micamp1 .....	13
5.1.2 AT+CMIC Microphone volume control .....	14
5.1.3 AT+CTXGAIN Set TX gain.....	15
5.1.4 AT+CTXFTR Set TX filter.....	15
5.1.5 AT+CTXVOL Set TX volume.....	16
5.2 Receiver or Speaker volume and frequency response.....	17
5.2.1 AT+CRXGAIN Set RX gain .....	17
5.2.2 AT+CRXFTR Set RX filter .....	18
5.2.3 AT+CVLVL Set value of sound level.....	19
5.2.4 AT+CLVL Loudspeaker volume level .....	20
5.2.5 AT+CRXVOL Set RX volume .....	21
5.3 AT+SIDET Digital attenuation of sidetone .....	22
5.4 Echo canceller .....	23
5.5 TDD noise .....	23
5.6 Sending and receiving distortion.....	25
5.7 DTMF distortion .....	25
6 Layout guide .....	26

## FIGURE INDEX

FIGURE 1: SPEAKER INTERFACE CONFIGURATION .....	8
FIGURE 2: RECEIVER INTERFACE CONFIGURATION .....	9
FIGURE 3: SIM5210 MIC INTERFACE CONFIGURATION .....	10
FIGURE 4: MICROPHONE INTERFACE CONFIGURATION .....	10
FIGURE 5: EARPHONE INTERFACE CONFIGURATION.....	11
FIGURE 6: AUDIO PROGRAMMING MODEL.....	12
FIGURE 7: SIM5218 PCB DECAL.....	24
FIGURE 8: MIRROR IMAGE OF PIN SEQUENCE.....	25

SIMCOM CONFIDENTIAL FILE

## Version history

Date	Version	Description of change	Author
2010-03-23	01.00	Origin	

SIMCOM CONFIDENTIAL FILE

## 1 Introduction

SIM52XX provides some AT commands for audio tuning. This document describes how to design and tune the audio part for best performance of SIMCOM WCDMA wireless module. (SIM52XX represents the series which is stated below.)

## 2 Scope of the document

This document is intended for the following versions of the SIMCom modules

- SIM5210
- SIM5211
- SIM5213/SIM5214
- SIM5215/SIM5216
- SIM5218
- SIM5220/SIM5222

### 3 Audio channel overview

The table below shows the audio channels of different SIMCOM WCDMA wireless modules.

Module	Audio Channel		Note
SIM5210 SIM5211 SIM5215 SIM5216 SIM5218	Handset: AT+CSDVC =1	Input: MIC1_P, MIC1_N Output: EAR_P, EAR_N	There is no MIC bias circuit for MIC input in SIM5210. So external MIC bias circuit is required. Detail description please refer to . This figure can be compatible with other SIMCOM WCDMA wireless modules. Except SIM5210, other SIMCOM WCDMA wireless modules has integrated internal MIC bias circuit. Detail description please refer to .
	Headset: AT+CSDVC=2	Input: HP_MIC Output: HPR, HPL	
	Handfree: AT+CSDVC=3	Input: MIC1_P, MIC1_N Output: SPK_P, SPK_N	
	PCM: AT+CSDVC=4	PCM_SYNC PCM_CLK PCM_DOUT PCM_DIN	
SIM5213 SIM5214	Handset: AT+CSDVC =1	Input: MIC1_P, MIC1_N Output: EAR_P, EAR_N	
	Handfree: AT+CSDVC=2	Input: MIC2_P, MIC2_N Output: SPK_P, SPK_N	
	PCM: AT+CSDVC=4	PCM_SYNC PCM_CLK PCM_DOUT PCM_DIN	
SIM5220 SIM5222	Handset: AT+CSDVC =1	Input: MIC1_P, MIC1_N Output: EAR_P, EAR_N	<b>Handset and PCM channel share the same hardware pins.</b>
	PCM: AT+CSDVC=4	PCM_SYNC PCM_CLK PCM_DOUT PCM_DIN	

## 4 Hardware Design

### 4.1 Speaker interface configuration

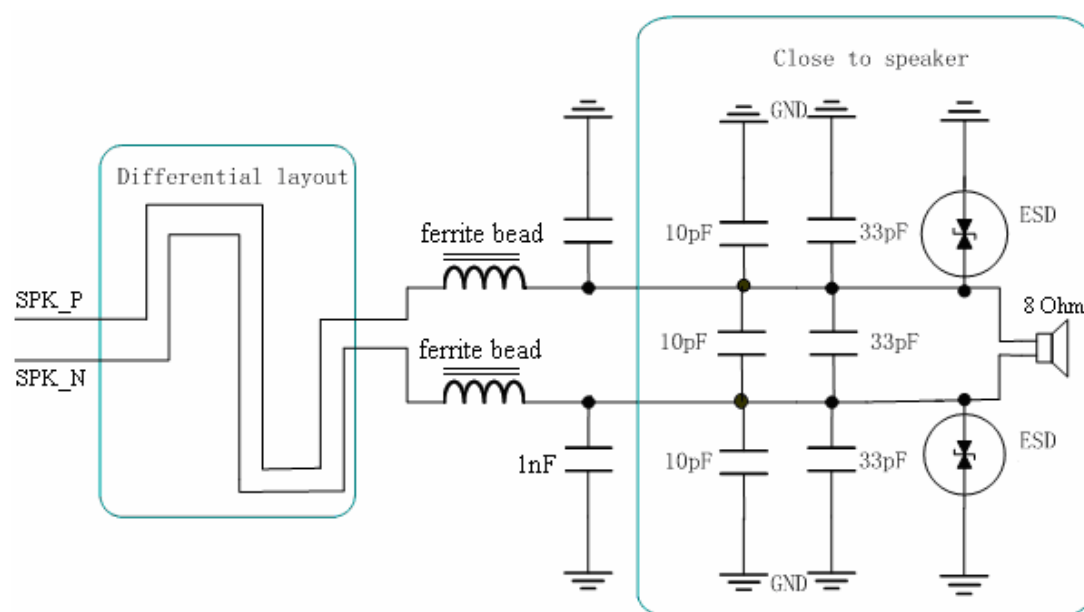

**Figure 1: Speaker interface configuration**

Because SPK\_P and SPK\_N are outputs of Class-D audio amplifier, optional EMI filtering is shown at Figure 1; these components (two ferrite beads and two capacitors) can be added to reduce electromagnetic interference. If used, they should be located near the SPK\_P and SPK\_N. Considerable current flows between the audio output pins and the speaker, so wide PCB traces are recommended (~ 20 mils). 8Ohm speaker is suggested. And the SPK\_P and SPK\_N should layout differential, and they should be far away from VBAT, RF signals, clock and other high power or high frequency signals.

### 4.2 Receiver interface configuration

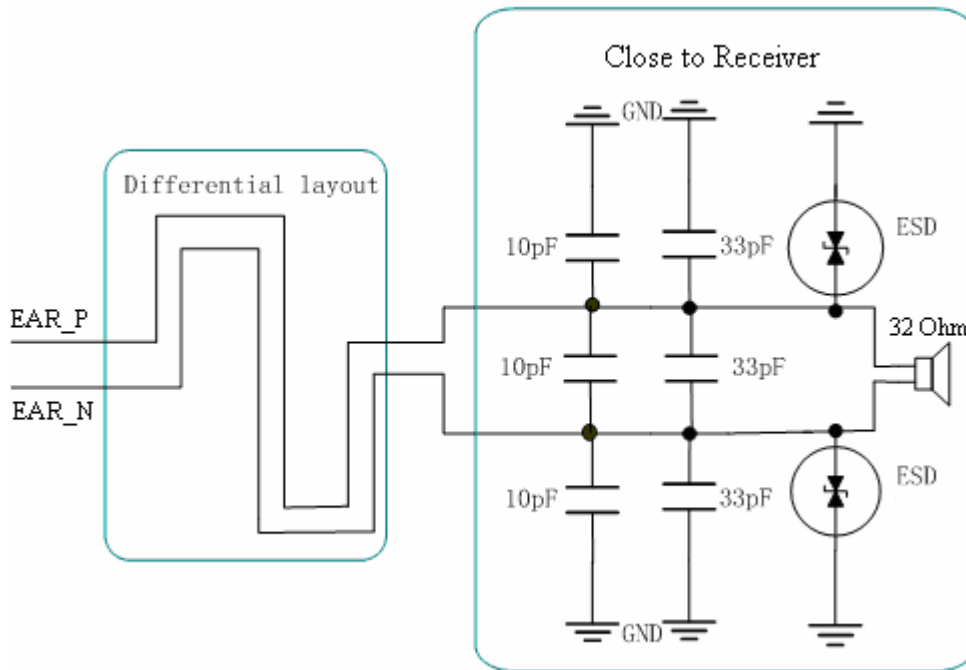

**Figure 2: Receiver interface configuration**

33p and 10p are suggested to be added beside the 32 Ohm receiver to reduce RF interfere. The width of EAR\_P and EAR\_N lines is typical 6 mils to reduce impedance. They should be far away from VBAT, RF signals, clock and other high power or high frequency signals. EAR\_P and EAR\_N lines should be layout differential.

### 4.3 SIM5210 Microphone interfaces configuration

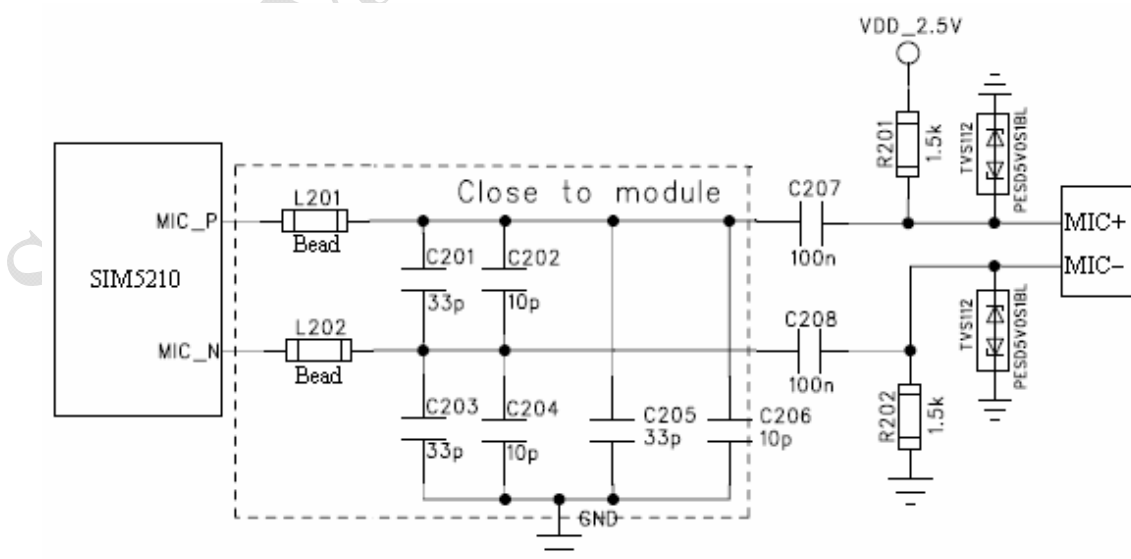

**Figure 3: SIM5210 MIC interface configuration**

There is no MIC bias circuit for MIC input in SIM5210. So external MIC bias circuit is required. This figure can be compatible with other SIMCOM WCDMA wireless modules. MIC\_P and MIC\_N should be layout differential.

**4.4 Microphone interfaces configuration (Except SIM5210)**

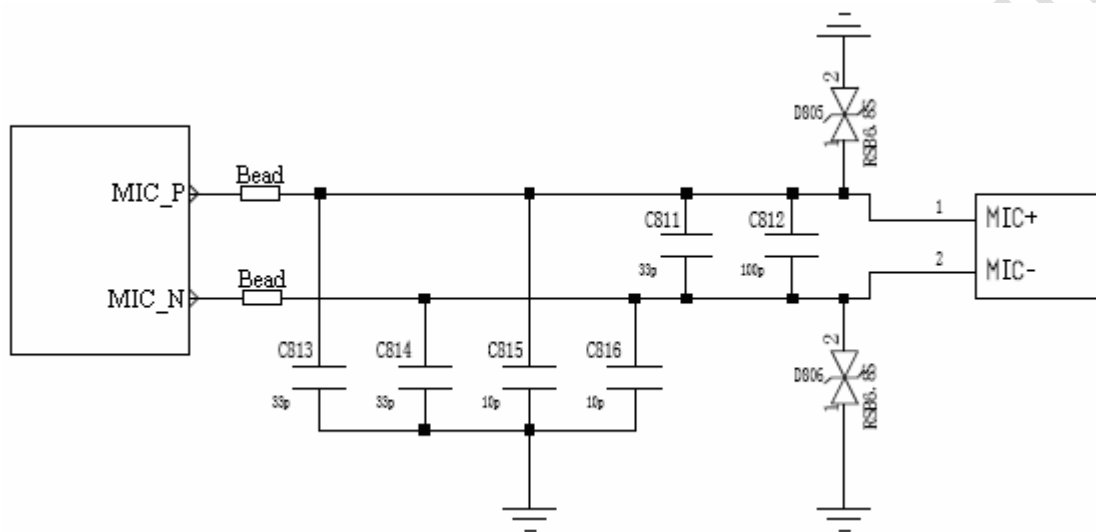

**Figure 4: Microphone interface configuration**

Except SIM5210, other SIMCOM WCDMA wireless modules have integrated internal MIC bias circuit. There is no need to pull the MIC1\_P and MIC\_M up to the external power, because they have been pulled up in the Module. MIC\_P and MIC\_N should be layout differential.



### Audio Application Note

	Differential	load Resistance	27	32		Ohm
	Single Ended	Output power		21.6		mW

**Table 3: Speaker Output Characteristics**

Parameter	Min	Typ	Max	Unit
Quiescent Current		6.2		mA
Output power(1KHz)		500		mW

## 5 Audio Tuning

The audio programming model shows how the signal path can be influenced by varying AT command parameters. Parameters  $\langle micAmp \rangle$ ,  $\langle txGain \rangle$ ,  $\langle txVol \rangle$ ,  $\langle txFilter \rangle$ ,  $\langle rxGain \rangle$ ,  $\langle stGain \rangle$ ,  $\langle rxVol \rangle$  and  $\langle rxFilter \rangle$  can be adjusted with corresponding AT commands. For more information on the AT commands and parameters see Section 3.8.5.1.

**NOTE:** Please reference document [1] for detailed information of each AT command.

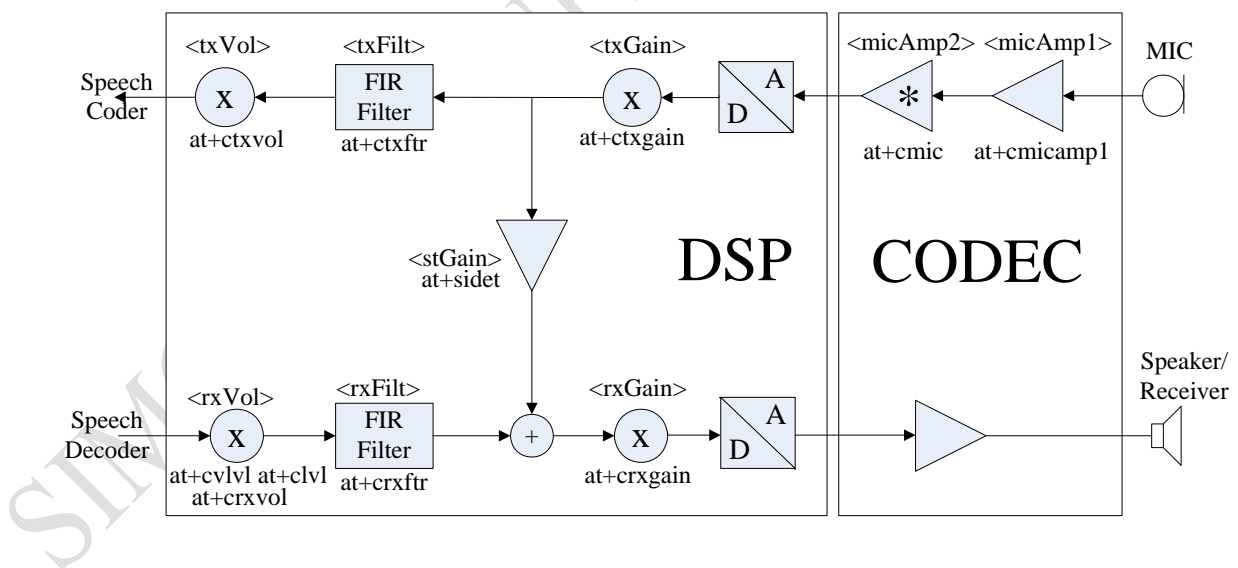

**Figure 6: Audio programming model**

- For SIM5211/SIM5213/SIM5214/SIM5215/SIM5216/SIM5222, there is no  $\langle micAmp2 \rangle$ , so at+cmic does not function.
- The parameters located in DSP, will not function until the next calling setup, such as at+ctxvol, at+ctxftr, at+ctxgain, at+clvl, at+cvlvl, at+crxftr, at+crxgain, at+sidet. And the

parameters located in codec can function in calling.

## 5.1 MIC volume and frequency response

In figure2, one can turn adjust codec part or DSP part parameters to get desired MIC volume or frequency response.

### Codec part

<micamp1>: AT+cmicamp1 (Detail description refer to 5.1.1)

<micamp2>: AT+cmic (Detail description refer to 5.1.2)

### DSP part

<txGain>: AT+ctxgain (Detail description refer to 5.1.3)

<txFilt>: AT+ctxftr (Detail description refer to 5.1.4)

<txVol>: AT+ctxvol (Detail description refer to 5.1.5)

**Note:** From figure2, one can see that AT+cmicamp1, AT+cmic, AT+ctxgain, AT+ctxftr, AT+ctxvol can influence sidetone.

### 5.1.1 AT+CMICAMP1 Set value of micamp1

#### Description

The command is used to set audio path parameter – micamp1; this is different with AT+CMIC. With this command you can change the first stage of MIC amplify value based on your design separately and refer to related hardware design document to get more information

SIM PIN	References
NO	Vendor

#### Syntax

Test Command	Responses
AT+CMICAMP1=?	+CMICAMP1: (list of supported <amp_val>s) OK
Read Command	Responses
AT+CMICAMP1?	+CMICAMP1:<amp_val> OK
Write Command	Responses
AT+CMICAMP1= <amp_val>	OK ERROR

#### Defined values

<amp\_val>

## Audio Application Note

amplify value number which is from 0 to 1. 0 is 0DB and 1 is 24DB.

### Examples

```
AT+CMICAMP1=0
```

```
+CMICAMP1: 0
```

```
OK
```

```
AT+CMICAMP1?
```

```
+CMICAMP1: 0
```

```
OK
```

```
AT+ CMICAMP1=?
```

```
+CMICAMP1: (0-1)
```

```
OK
```

### 5.1.2 AT+CMIC Microphone volume control

#### Description

The command is used to control the microphone gain level. When the Module restarts, the gain level will resume as default values. The setting will be saved to nonvolatile memory after write command is executed. There is at+cmic in SIM5211/SIM5213/SIM5214/SIM5215/SIM5216/SIM5222.

SIM PIN	References
NO	Vendor

#### Syntax

Test Command	Responses
AT+CMIC=?	+CMIC: (list of supported <gainLevel>s) OK
Read Command	Responses
AT+CMIC?	+CMIC: <gainLevel> OK
Write Command	Responses
AT+CMIC=<gainLevel>	OK ERROR

#### Defined values

<gainlevel>

Range from 0 to 15, and 0 is the lowest gain level.

When the audio output of device is handset, 7 is default value; when headset, 7 is default value; when speaker, 4 is default value.

## Examples

```
AT+CMIC=5
OK
AT+CMIC ?
+CMIC:5
OK
```

### 5.1.3 AT+CTXGAIN Set TX gain

#### Description

The command is used to set audio path parameter – TX gain, and refer to related hardware design document to get more information.

SIM PIN	References
NO	Vendor

#### Syntax

Test Command	Responses
AT+CTXGAIN=?	+CTXGAIN: (list of supported <tx_gain>s) OK
Read Command	Responses
AT+CTXGAIN?	+CTXGAIN: <tx_gain> OK
Write Command	Responses
AT+CTXGAIN=<tx_gain>	OK

#### Defined values

<tx\_gain>  
TX gain level which is from 0 to 65535.

#### Examples

```
AT+CTXGAIN=1234
OK
```

### 5.1.4 AT+CTXFTR Set TX filter

#### Description

## Audio Application Note

The command is used to set audio path parameter – TX filter, and refer to related hardware design document to get more information.

SIM PIN	References
NO	Vendor

## Syntax

Test Command	Responses
AT+CTXFTR=?	+CTXFTR: (list of supported <tx_ftr_N>s) OK
Read Command	Responses
AT+CTXFTR?	+CTXFTR: <tx_ftr_1>,<...>,<tx_ftr_7> OK
Write Command	Responses
AT+CTXFTR= <tx_ftr_1>,<...>,<tx_ftr_7>	OK

## Defined values

<tx_ftr_X>
TX filter level which is from 0 to 65535. (N is from 0 to 7)

## Examples

AT+CTXFTR=1111,2222,3333,4444,5555,6666,7777
OK

### 5.1.5 AT+CTXVOL Set TX volume

## Description

The command is used to set audio path parameter – TX volume, and refer to related hardware design document to get more information.

SIM PIN	References
NO	Vendor

## Syntax

Test Command	Responses
AT+CTXVOL=?	+CTXVOL: (list of supported <tx_vol>s) OK

## Audio Application Note

Read Command	Responses
AT+CTXVOL?	+CTXVOL: <tx_vol> OK
Write Command	Responses
AT+CTXVOL=<tx_vol>	OK

## Defined values

<tx\_vol>

TX volume level which is from 0 to 65535.

## Examples

```
AT+CTXVOL=1234
```

```
OK
```

## 5.2 Receiver or Speaker volume and frequency response

In figure2, one can only turn adjust DSP part parameters to get desired receiver or speaker volume and frequency response. The parameter of codec part of module can not be adjusted.

### DSP part

<rxGain>:	AT+crxgain	(Detail description refer to )
<rxFilt>:	AT+crxftr	(Detail description refer to )
<rxVol>:	AT+cvlvl,	(Detail description refer to )
	AT+clvl,	(Detail description refer to )
	AT+crxvol	(Detail description refer to )

*Note: From figure2, one can see that at+crxgain can influence sidetone.*

**AT+crxvol is used for fine tuning for <rxVol>. AT+CLVL and AT+CVLVL are used for coarse tuning for <rxVol>.** Although we provide some AT for adjust the volume such as CRXVOL and CRXGAIN. These commands can change the voice levels together, that is to say, all the levels are promoted by these two parameters. But if you want to change each sound level value, you should use command CVLVL.

**AT+CVLVL** This command changes the sound level values of the command CLVL. Now we provide 5 levels for each audio channel. The level 0 is muted and it can not be changed by CVLVL. Levels 1 to 4 are supported to change the value of sound level. CVLVL command could let you change these four levels. The bigger the number presents the louder the voice. And the range of each level is -5000 to 5000.

### 5.2.1 AT+CRXGAIN Set RX gain

#### Description

## Audio Application Note

The command is used to set audio path parameter – RX gain, and refer to related hardware design document to get more information.

SIM PIN	References
NO	Vendor

## Syntax

Test Command	Responses
AT+CRXGAIN=?	+CRXGAIN: (list of supported <rx_gain>s) OK
Read Command	Responses
AT+CRXGAIN?	+CRXGAIN: <rx_gain> OK
Write Command	Responses
AT+CRXGAIN=<rx_gain>	OK

## Defined values

<rx_gain>
RX gain level which is from 0 to 65535.

## Examples

AT+CRXGAIN=1234
OK

### 5.2.2 AT+CRXFTR Set RX filter

#### Description

The command is used to set audio path parameter – RX filter, and refer to related hardware design document to get more information.

SIM PIN	References
NO	Vendor

## Syntax

Test Command	Responses
AT+CRXFTR=?	+CRXFTR: (list of supported <rx_ftr_N>s) OK
Read Command	Responses
AT+CRXFTR?	+CRXFTR: <rx_ftr_1>,<...>,<rx_ftr_7>

## Audio Application Note

	OK
Write Command	Responses
AT+CRXFTR= <rx_ftr_1>,<...>,<rx_ftr_7>	OK

## Defined values

<rx\_ftr\_X>

RX filter level which is from 0 to 65535. (N is from 0 to 7)

## Examples

AT+CRXFTR=1111,2222,3333,4444,5555,6666,7777

### 5.2.3 AT+CVLVL Set value of sound level

#### Description

The command is used to set audio path parameter – RX volume; this command is different from CRXVOL, command CRXVOL will modify the values of all sound levels offset we provided together. With this command you can change the value of each sound level based on your design separately and refer to related hardware design document to get more information.

**AT+crxvol is used for fine tuning for <rxVol>. AT+CLVL and AT+CVLVL are used for coarse tuning for <rxVol>.** Although we provide some AT for adjust the volume such as CRXVOL and CRXGAIN. These commands can change the voice levels together, that is to say, all the levels are promoted by these two parameters. But if you want to change each sound level value, you should use command CVLVL.

SIM PIN	References
NO	Vendor

#### Syntax

Test Command	Responses
AT+CVLVL=?	+CVLVL: (list of supported <lvl>s),(list of supported <lvl_v-alue>s) OK
Read Command	Responses
AT+CVLVL?	+CVLVL: <lvl_value1>,<lvl_value2>,<lvl_value3>,<lvl_value4> OK
Write Command	Responses
AT+CVLVL= <lvl>, <lvl_value>	OK ERROR

## Defined values

## Audio Application Note

<lvl>	sound level number which is from 1 to 4.
<lvl_value>	sound level value which is from -5000 to 5000.
<lvl_value1>	sound level value that sound level number equals 1.
<lvl_value2>	sound level value that sound level number equals 2.
<lvl_value3>	sound level value that sound level number equals 3.
<lvl_value4>	sound level value that sound level number equals 4.

## Examples

```
AT+CVLVL=1,-2000
+CVLVL: -2000
OK
AT+CVLVL?
+CVLVL: -2000,-200,500,1000
OK
AT+ CVLVL=?
+CVLVL: (1-4),(-5000~5000)
OK
```

### 5.2.4 AT+CLVL Loudspeaker volume level

#### Description

Write command is used to select the volume of the internal loudspeaker audio output of the device.

Test command returns supported values as compound value.

SIM PIN	References
NO	3GPP TS 27.007

#### Syntax

Test Command	Responses
AT+CLVL=?	+CLVL: (list of supported <level>s) OK
Read Command	Responses
AT+CLVL?	+CLVL: <level> OK

## Audio Application Note

Write Command	Responses
AT+CLVL=<level>	OK
	ERROR

## Defined values

<level>

Integer type value which represents loudspeaker volume level. The range is from 0 to 4, and 0 represents the lowest loudspeaker volume level, 2 is default factory value.

**NOTE** <level> is nonvolatile, and it is stored when restart.

## Examples

```
AT+CLVL?
```

```
+CLVL:2
```

```
OK
```

```
AT+CLVL=3
```

```
OK
```

## 5.2.5 AT+CRXVOL Set RX volume

### Description

The command is used to set audio path parameter – RX volume, and refer to related hardware design document to get more information.

SIM PIN	References
NO	Vendor

### Syntax

Test Command	Responses
AT+CRXVOL=?	+CRXVOL: (list of supported <rx_vol>s) OK
Read Command	Responses
AT+CRXVOL?	+CRXVOL: <rx_vol> OK
Write Command	Responses
AT+CRXVOL=<rx_vol>	OK

## Defined values

<rx\_vol>

## Audio Application Note

RX volume level which is from -100 to 100.

### Examples

```
AT+CRXVOL=12
OK
```

## 5.3 AT+SIDET Digital attenuation of sidetone

### Description

The command is used to set digital attenuation of sidetone. For more detailed information, please refer to relevant HD document.

SIM PIN	References
NO	Vendor

### Syntax

Test Command	Responses
AT+SIDET=?	+SIDET: (list of supported <st>s) OK
Read Command	Responses
AT+SIDET?	+SIDET:<st> OK
Write Command	Responses
AT+SIDET= <st>	OK ERROR

### Defined values

<st>

Digital attenuation of sidetone, integer type in decimal format and nonvolatile.

Range: from 0 to 65535.

Factory value: HANDSET:2034, HEADSET:1024, SPEAKER PHONE: 0.

### Examples

```
AT+CSDVC=1
OK
AT+SIDET?
+SIDET: 2304
OK
```

## 5.4 Echo canceller

SIM52xx has not provided AT command to adjust echo canceller. If one has encountered some problems with echo canceller, one can contact us for help.

## 5.5 TDD noise

Making sure the module connect to ground well can help to reduce the TDD noise and improve ESD.

Below we take SIM5218 as an example to explain how to reduce TDD noise. There are 4 out-feet of SIM5218A bottom shield. One can solder them to bare copper on host board, so that SIM5218A can be connected to the ground well. Figure 7 is SIM5218 PCB decal we suggest. There a large piece of copper to help connecting well with SIM5218 bottom shield.

Because the height of 70- pins plug on SIM5218A is 1.5mm, in order to better connecting the SIM5218A with to the ground of the host board well, it is suggested to choose 2.0mm height 70-pins socket for host board. NAS AXK770247G is suitable. 2.5mm will be too high, it will be suspending above host board. 1.5mm will be too tight.

Filtering capacitors and beads are suggested to be added in the audio lines, 33p and 10p can help reduce the 850Mhz and 1800Mhz RF interfere. If it is signal, the filtering capacitors and beads are suggested to add beside the module pins. If it is output trace, the filtering capacitors and beads are suggested to add beside the handset/ headset/speaker connector.

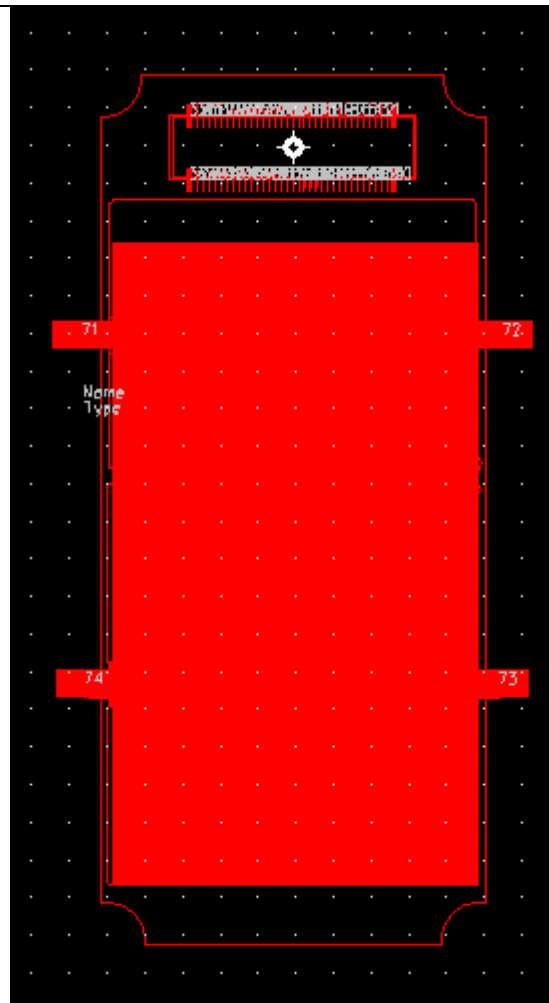

**Figure 7: SIM5218 PCB decal**

When one mounts SIM5218A on host board, please pay attention to that the pin sequence of SIM5218A is mirror image of pin sequence of 70-pin socket connector on host.

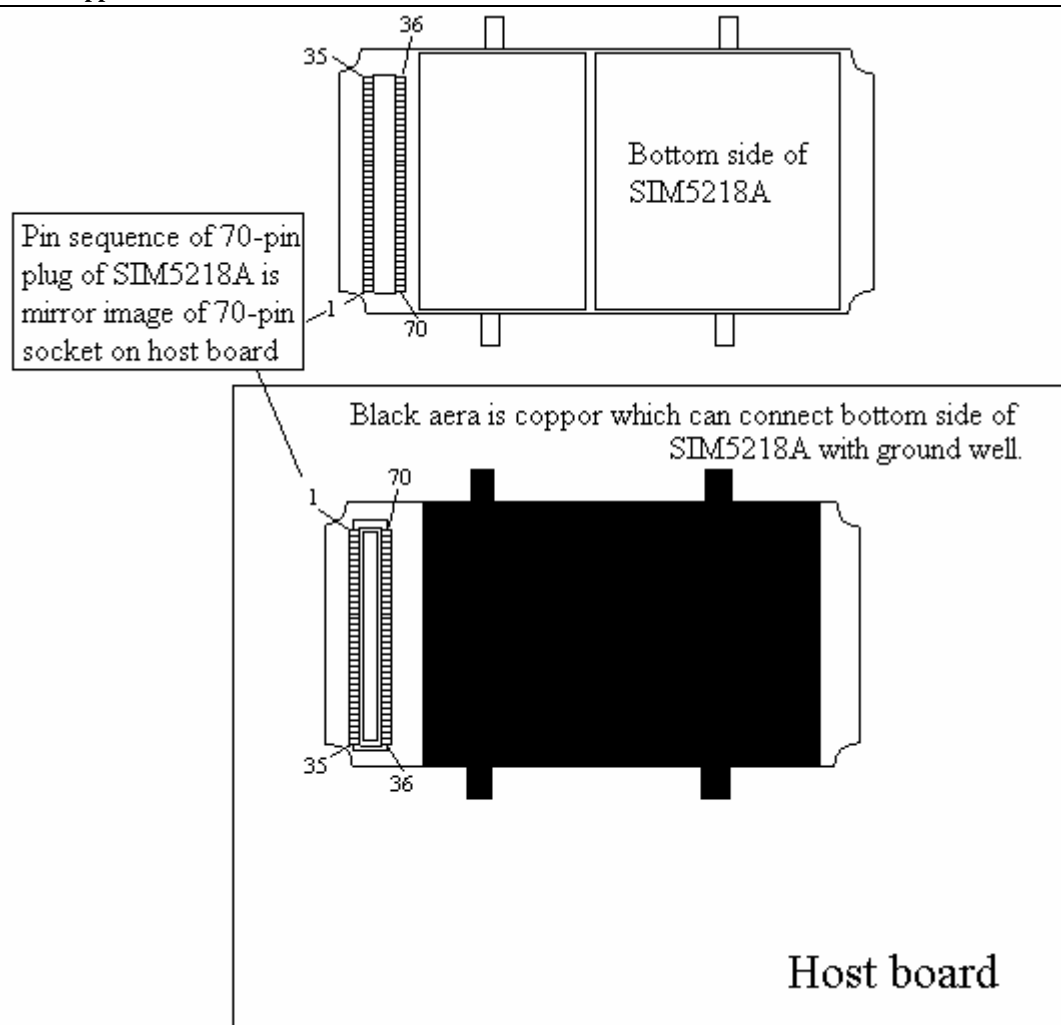

**Figure 8: Mirror image of pin sequence**

## 5.6 Sending and receiving distortion

There are many factors which may influence the sending and receiving distortion.

1. Unsuitable FIR parameters. They can be adjust by AT+CTXGAIN, AT+CRXGAIN.
2. Too large TDD noise. Please refer to 5.5 for solution.
3. Unbalance parameters between <txGain> and <txVol> for receiving, and unbalance parameters between and <rxGain> and <rxVol> for sending.

For example, if one find sending distortion which are not caused by unsuitable FIR parameters and TDD noise, one can adjust <txGain> and <txVol> to a “balance” value. Here “unbalance” means one of <txGain> and <txVol> is set too large, and another is set too small.

## 5.7 DTMF distortion

Too large sending and receiving gain may result in DTMF distortion.

### **Audio Application Note**

---

If one find DTMF sending distortion which can be measured by the oscillograph in receiving end, one can turn off the <micamp1> and try again. Other sending parameters can also be adjusted to get better DTMF performance.

If one find DTMF receiving distortion, on can adjust receiving parameters to get better DTMF performance.

## **6 Layout guide**

The audio signals are sensitive to RF signals and power sources (for example Vbat). Please make sure that the audio signals are far away from the RF signals and Vbat. And the output signals and input signals should be kept away from each other by ground. The differential lines should be layout together. And HPL and HPR are not differential signals, so they should be layout separately.

Filtering capacitors and beads are suggested to be added in the audio lines, 33p and 10p can help reduce the 850Mhz and 1800Mhz RF interfere. If it is signal, the filtering capacitors and beads are suggested to add beside the module pins. If it is output trace, the filtering capacitors and beads are suggested to add beside the handset/ headset/speaker connector.

One can send design to us for checking.

**Contact us:**

**Shanghai SIMCom Wireless Solutions Ltd.**

Add: Building A, SIM Technology Building, No.633, Jinzhong Road, Changning District, Shanghai, P. R. China 200335

Tel: +86 21 3235 3300

Fax: +86 21 3235 3301

URL: [www.sim.com/wm](http://www.sim.com/wm)

SIMCOM CONFIDENTIAL FILE