

SV TEHS SIA

Development Tools for Java™

IPVES Application Note 15:

Halvanic isolation

SV TEHS SIA

IPJV-ES Application Note 15: Halvanic isolation

V 1.0

© SV TEHS SIA

Ruses 14-24 • LV1029 • Riga • Latvia

Phone: +371-9223895 • Fax: +371-7332773

Email: info@svtehs.com • Web: <http://www.svtehs.com>

IPJVM and IPJV-ES are trademarks of SV TEHS SIA. ipStack, ipOS are trademarks of Ubicom, Inc. Java™ and all Java™-based marks are trademarks or registered trademarks of Sun Microsystems, Inc. in the U.S. and other countries. All other trademarks are property of their respective owners.

Introduction

IPJV-ES Development Board can be used in different applications.

The IPJV-ES Development Board with embedded virtual machine for Java™ offers an Ethernet based connection to the Internet and numerous interface possibilities to other equipment, include serial RS-232 DTE interface, serializer module with UART, SPI, GPSI and 10BASE-T Ethernet support, 6-channel 10-bit A/D inputs, analog comparator and 16 I/O pins.

The IPJVM virtual machine for Java is a clean room implementation, that has been specially optimized to run on device with limited amount of internal memory and designed for Java™ 2 Platform, Micro Edition (J2ME™) Connected Device Configuration (CDC) Foundation Profile.

A complete development toolkit available for application development with IPJVM platform. The IPJVM platform provide system designers and software developers simple, flexible and cost-effective solution for embedded Internet application rapid development and prototyping. The platform is combination of Uvicom IP2022 Internet Processor and a Java programmable runtime environment.

The IPJV-ES Development Board based on Uvicom IP2022 Internet Processor, optimized for Internet-edge applications. It handles protocol processing in software instead of in hard-wired logic, making the whole solution more adaptable to evolving standards and allow designer to use the same solution across a wide variety of internet-edge products simply by changing the software, thereby significantly reducing nonrecurring engineering (NRE) costs.

Typical IPJV-ES applications include Includes HTTP/FTP/SMTP/SNMP/Telnet servers, PPP support on embedded UARTs, encryption, security and authentication tools, reporting and alarming via e-mail, remote monitoring, control, management and maintenance.

Updates

New versions of the IPJV-ES software and applications can be obtained from the manufacturer's web site at:

<http://www.svtehs.com/ipjv.htm>

Halvanic isolation

RS-232 applications isolation described.

The RS-232 bus standard is one of the most popular serial communication bus designs. Because the RS-232 standard is typically used as an intersystem connection, isolation between the bus and each system connected is critical. Digital isolation provides crucial isolation and protection from overvoltage transients between the RS-232 cable bus and the system connected to it. Digital isolation also eliminates ground loops on the RS-232 bus. Digitally isolating the RS-232 bus from the system connected to the bus reduces signal distortion and errors, and provides system and component protection from system and bus voltage and ground mismatches.

IPJV board have one build-in UART with on-board connector. It is also possible to use second UART on the extension connector. Firmware with 2 UARTs support should be downloaded (see Chapter 6 of the IPJV User's Guide for details). This application describe second UART halvanic isolation.

The ADuM1402 4-channel digital isolator from Analog Devices used for signal isolation. This isolation component remove all design difficulties, commonly associated with optocouplers and consume significantly less power. ADuM1402 provide four indepent isolation channels (two inputs and two outputs on each side). It also ensure DC correctness in the absence of input logic transitions and during power-up/power-down conditions.

For standard RS232 levels ADM202 two-channel RS-232 driver/receiver pair from Analog Devices used. This component can operate from a single +5V power supply at speed up to 200kBPS.

Power requirements of the isolated side is very small, so 0.25W DC/DC converter will be enough. LME0505D from CD Technologies is good example of this converter. Due to low quiescent current, it can offer up to 75% efficiency.

HALVANIC ISOLATION

Typical isolated RS-232 schematic shown on the picture below:

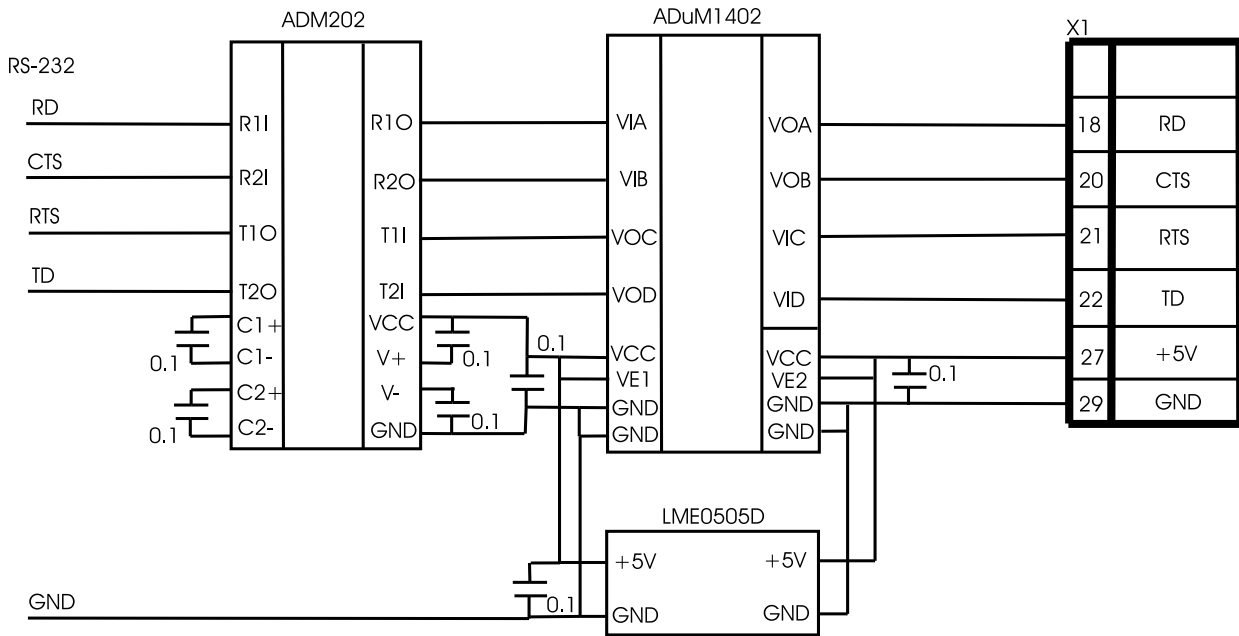

Table of Contents

1. Introduction	1
Updates	1
2. Halvanic isolation	2